

I M M E R S E

The **Bible** Reading Experience™

Preparing My Home for the Storm

Matt 7:24 - 29

(Pg 323)

1. Everyone goes through storms. The challenge is to allow my storm to teach me about God and prepare me for the next storm.

A. *Two homes. V 24, 26*

B. *One storm. V25, 27*

C. *Two different foundations.*

D. *Two different results.*

E. *What about Jesus and storms?*





- Has your relationship to Jesus given you a new way to define *whose* you are? ?

A. As “living stones” we are (v2:9):

- *Chosen* people.
- Royal *priests*.
- *Holy* nation.
- *Belonging* to Jesus.
- *Grouped* in fellowship.

2. What do you see as the *primary barrier* to strengthening your foundation, i.e., your *personal refuge* in a storm?

- A. *Listening vs hearing.*
- B. *Wrong thinking.*
- C. *Impenetrable. Firewalls.*

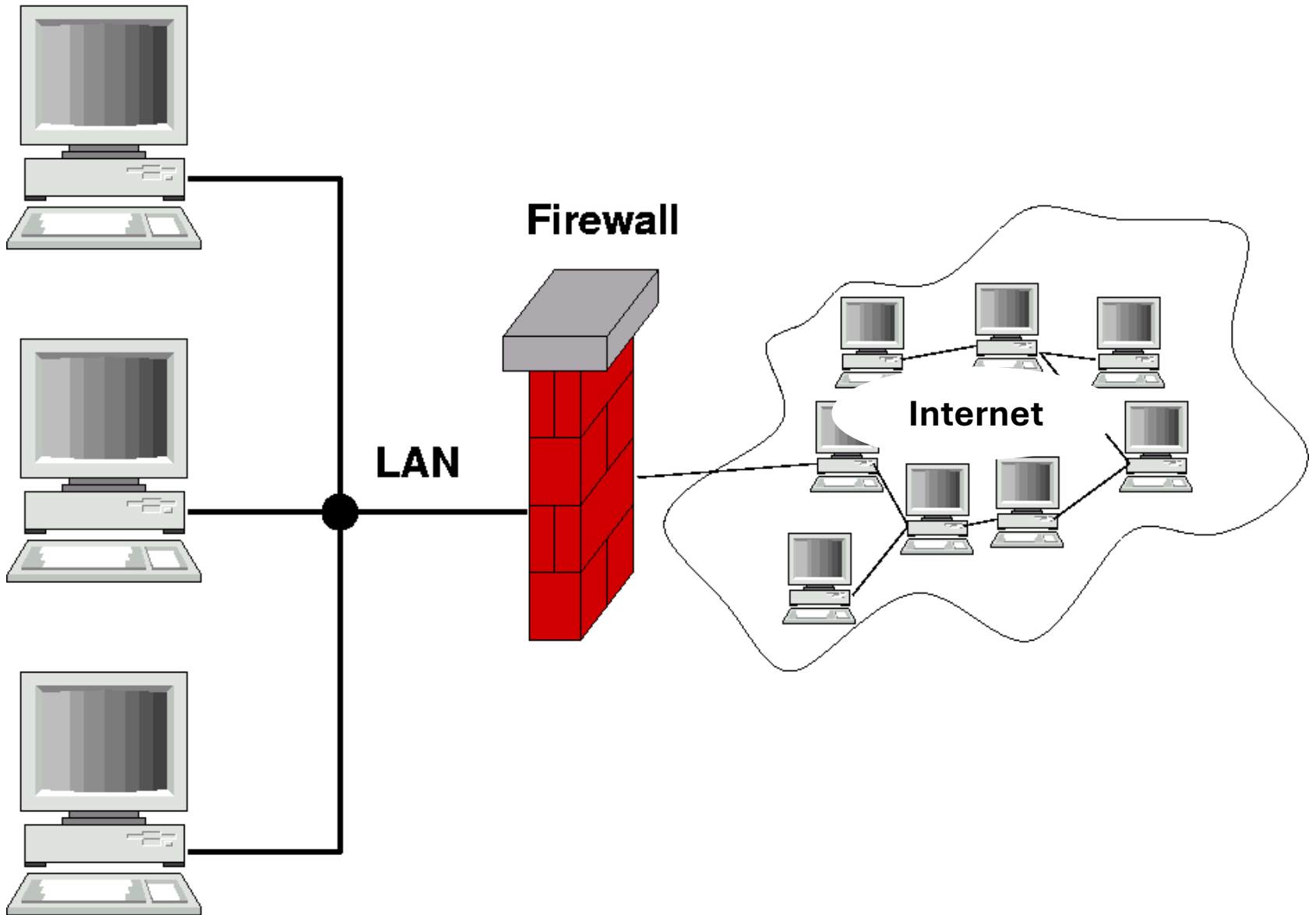

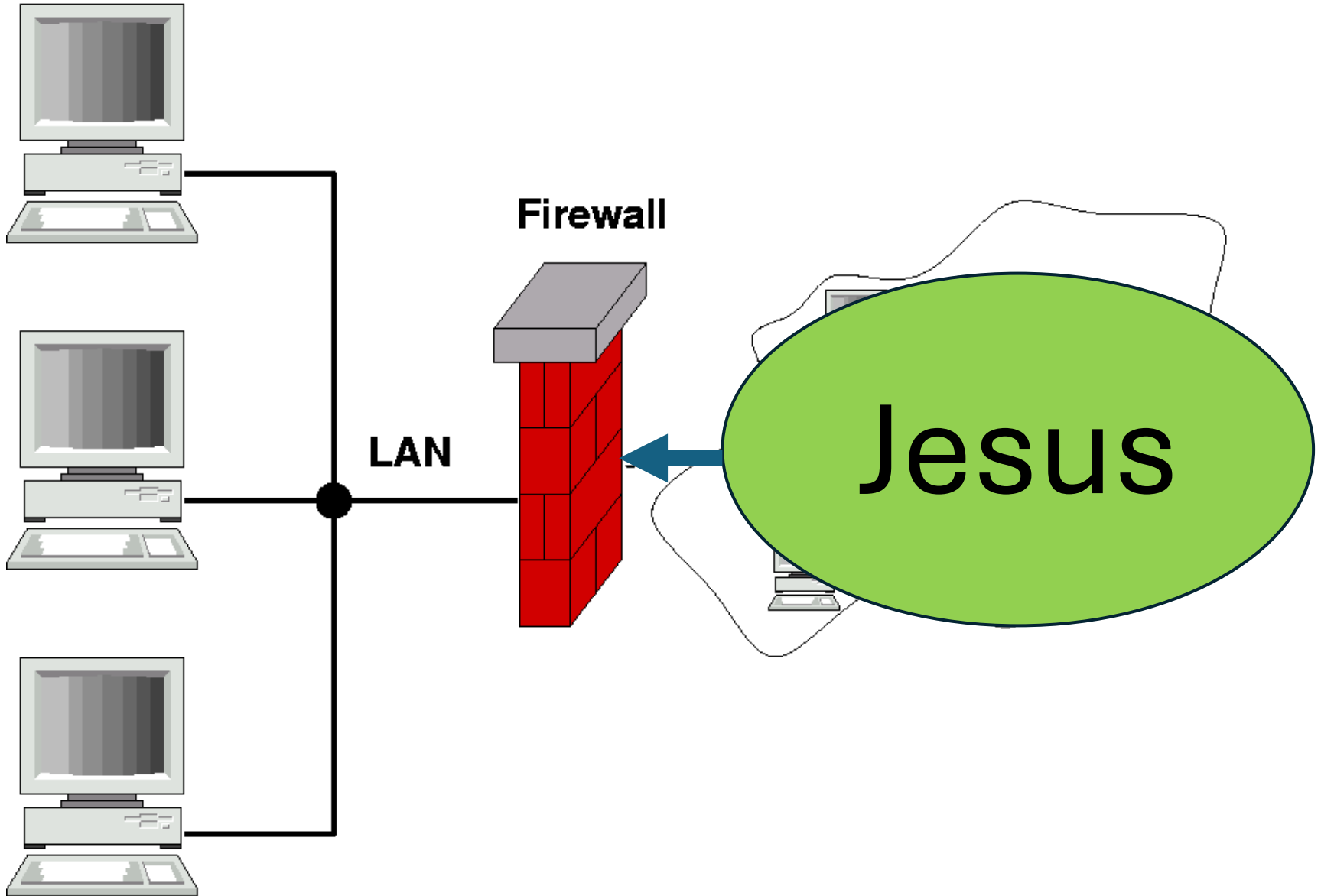

3. How are you doing with your fear? Is fear what your “firewall” is composed of?

A. *Fear blinds faith.*

B. *Puts us in stuck mode.*

C. *Assumes the worst.*

D. *Fear turns us against one another.*

Next steps – Make Jesus and the Body of Christ my refuge in my storm.

- A. *Reject my assumptions – based on fear. Refuse to accept the worst case.*
- B. *Replace my fear messages with the Word of God. Ps 20:7-8, 91:2, Matt 11:28-29*
- C. *Pray wo ceasing. Record it a prayer journal.*
- D. *Pay attention to the HS around you.*
- E. *Surround myself with like minded believers who will pray with me and hold me accountable.*